

The SALA series of  
Vertical tank pumps





Rubber lined & hard metal

# Vertical tank pumps

The Metso VT, vertical tank, pumps are designed for abrasive slurry service and feature simple main-tenance and robust design.

The ingenious design of the pump makes it exceptionally service friendly and easy to install. Metso is now introducing the

next generation of integrated Vertical Tank Pump VT, developed from the old SALA tank pump SPV.

## Summary of design features

- Integrated unit for layout flexibility
- Smooth operation of open sump and vertical inlet which prevents air blocking
- Cantilever design without submerged bearings or shaft seals
- Bearing assembly with double protection sealing arrangement to prevent ingress of slurry
- Wear parts are available in a variety of different materials and are fully interchangeable
- Simplified maintenance features

## Pump designation

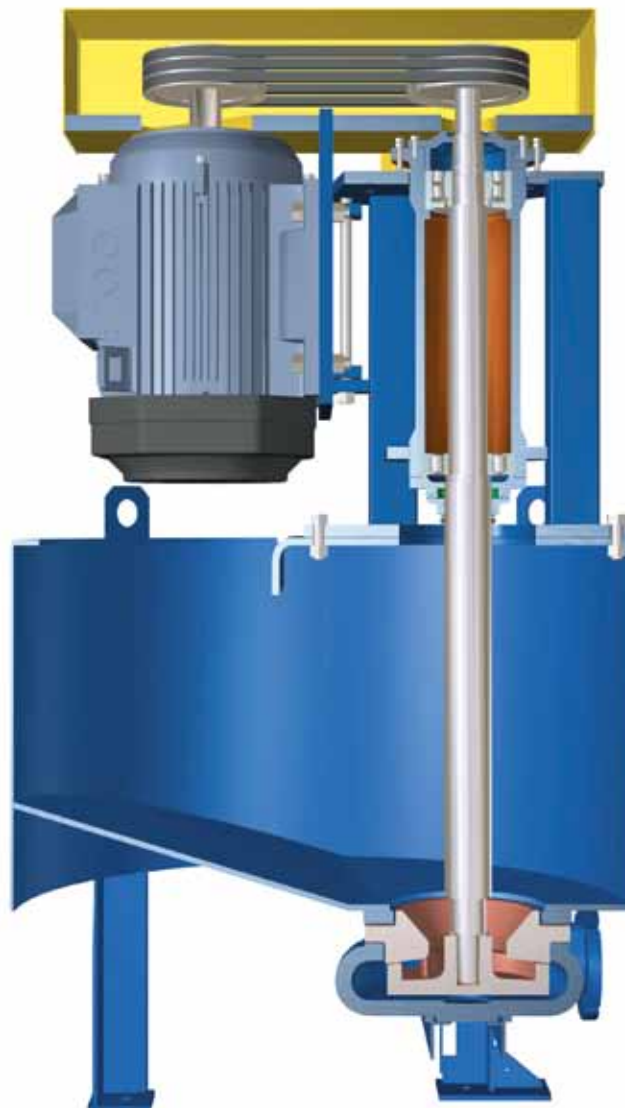
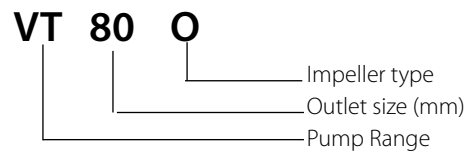

## Wear parts in the VT-pump

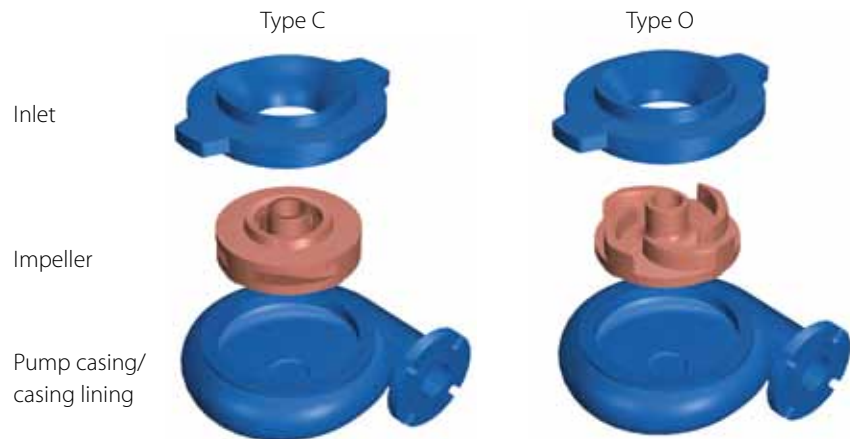

## Details of design features

### Layout flexibility

The pump, pump sump and motor are integrated in one self-contained unit. Simple to install and connect. No alignment or special foundations needed.

### Smooth operation

The open tank design with a vertical “wet end” inlet prevents air blocking by allowing entrained air to run up the shaft. These pumps can run dry.

### Cantilever design

The heavy duty pump shaft is a cantilever design, hanging below the bearing housing. There are no submerged bearings, stuffing box or shaft seals. This design ensures minimum maintenance and eliminates any requirement for water flushing.

### Bearing assembly

The pump shaft is carried in grease lubricated anti-friction bearings.

Impeller clearance is maintained by external axial adjustment of the shaft/bearing assembly. Bearings have double protection against ingress of slurry.

### Impeller options

Two different impeller options are available.

- Semi open impeller Type O for smooth and blockage free operation.
- Closed impeller Type C which features high head and efficiency.

## Materials

Standard pumps are supplied with “wet end” parts in wear resistant Natural Rubber or Wear Resistant High Chrome Iron alloy, with a nominal hardness of 600 BHN).

Two different impeller configurations are available for optimum performance, the Type O (open) and the Type C (closed).

Other wear part materials available include the Metso range of Natural Rubbers, Synthetic rubbers and Polyurethane.

The wear parts have large material sections for extra long wear life and are designed for the toughest applications.

Parts in different materials are fully interchangeable and can be combined for optimum life.

## Drive

Pumps are supplied with a Vee-belt drive, motor and drive guard. The motor is mounted vertically, with shaft up, on an adjustable motor plate fitted above the tank top, along side the bearing housing.

## Simplified maintenance

The casing on the VT tank pump is supported by a beam.

The beam is either lowered by hand or a hydraulic jack, depending on the pump size. On larger pump sizes (VT 100 and upwards) the beam can be swung out so that the “wet end” parts can be accessed by a lifting device.



## Options:

- "Wet End" materials
- Open or closed impellers
- Rubber lined tank and shaft for wear protection
- All rubber lined acid duty version
- Tank cover

## Typical installations

- Feed to dewatering cyclones in sand plants
- Screen underflow duties
- Sampling pumps in concentrators
- Permanent, mobile or semi-mobile installations in industrial applications
- Mixing/distribution units in applications for flocculent or lime in sewage plants or cement grouting in tunnels or mines

## Motor size

Motor size and V-belt drive vary with the pump application. Minimum data required for an approximate pump, speed and drive motor selection:

- Slurry flow rate
- Slurry density
- Total discharge head

## Other pump products

- XR, HR, MR Rubber Lined Pumps
- XM, HM, MM Hard Metal Pumps
- VS Vertical Sump Pumps
- VF Vertical Froth Pumps



## Selection of pump size and pump dimensions VT vertical tank pump range

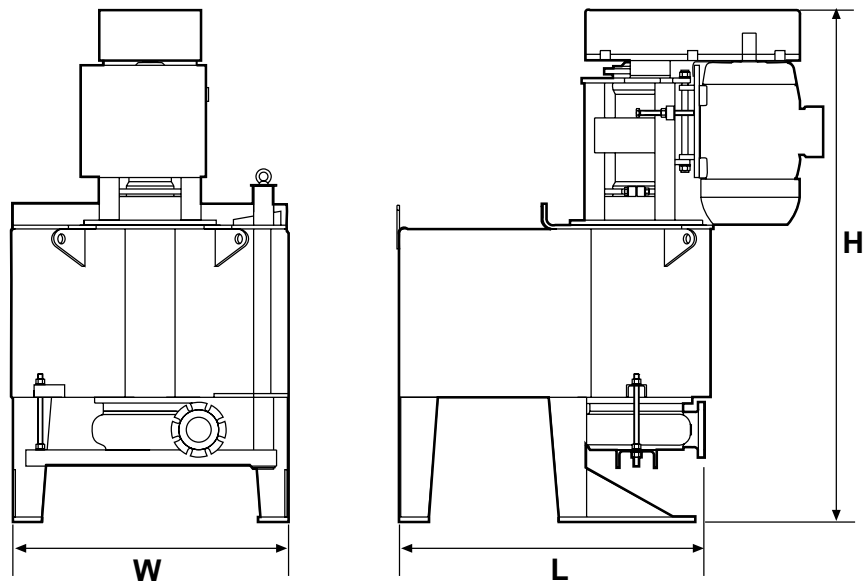
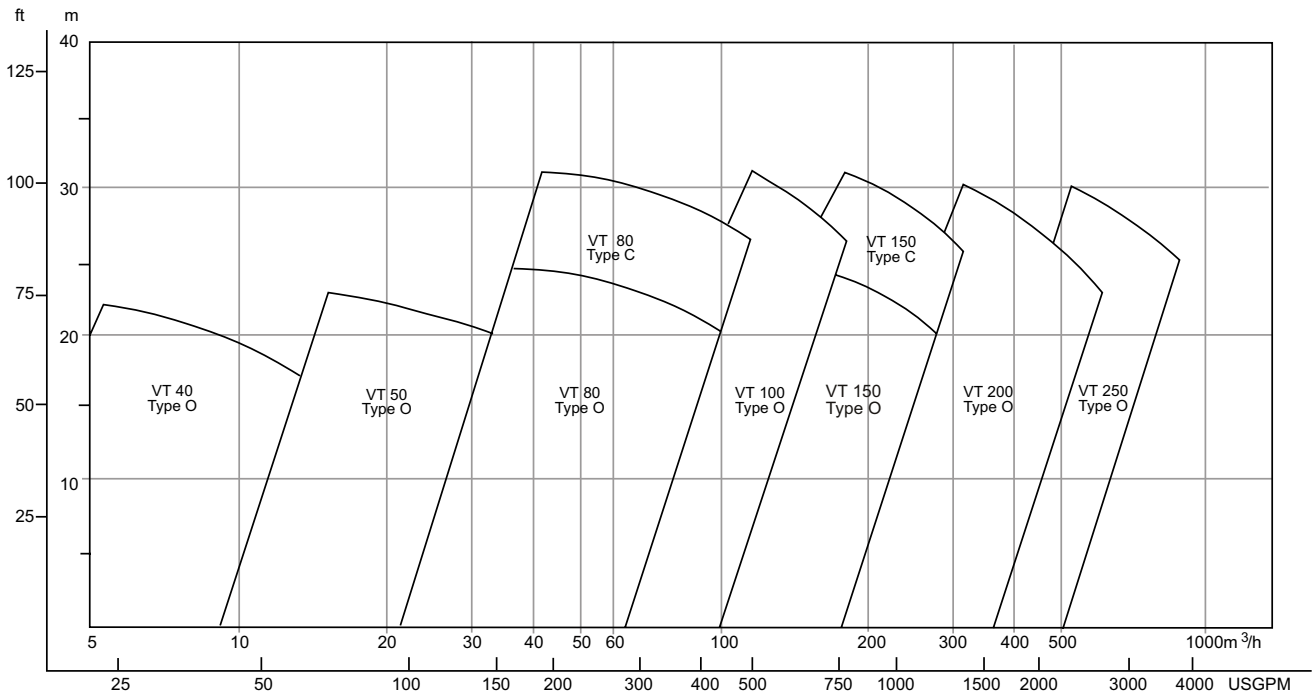

Pump size	H		L		W		Weight*		Sump volume			
	mm	inch	mm	inch	mm	inch	kg	lb	m <sup>3</sup>	USG		
VT 40	40	1.5 lab	955	37,5	640	25	400	16	90	198	0,03	8
VT 40	40	1.5	1 030	40,5	740	29	610	24	110	243	0,06	16
VT 50	50	2	1 470	58	1 035	41	1 010	40	305	672	0,25	66
VT 80	80	3	1 880	74	1 015	40	1 060	42	580	1 279	0,33	87
VT100	100	4	2 050	81	1 225	48	1 100	43	825	1 819	0,57	150
VT150	150	6	2 160	85	1 285	50,5	1 100	43	925	2039	0,57	150
VT200	200	8	3 105	122	1 710	67	1 510	59	2 655	5 853	1,26	333
VT 250	250	10	3 105	122	1 760	69	1 510	59	2 785	6 140	1,26	333

\* Weight figures are for metal parts. For rubber parts reduce weight by 10%.



- **Metso Minerals (Sweden) AB**  
Norrängsgatan 2, SE-733 38 Sala, Sweden, Phone: +46 224 374 00, Fax: +46 224 169 69
- **Metso Minerals Industries Inc.**  
4820 Centennial Blvd, Suite 115, Colorado Springs, Co 80919-3351, USA, Phone: +1 719 471 3443, Fax: +1 719 471 4469
- **Metso Minerals Industries Inc.**  
P.O. Box 96, Birmingham, AL 35201, USA, Phone: +1 205 599 6600, Fax: +1 205 599 6623
- **Metso Minerals (South Africa) (Pty) Ltd.**  
Private Bag X2006, Isando, Johannesburg, 1600, South Africa, Phone: +27 11 961 4000, Fax: +27 11 397 2050
- **Metso Minerals (Australia) Ltd.**  
Level 2, 1110 Hay Street, West Perth, WA 6005, Australia, Phone: +61 8 9420 5555, Fax: +61 8 9320 2500
- **Metso Minerals (India) Pvt Ltd**  
1th floor, DLF Building No. 10, Tower A, DLF Cyber City, Phase - III, Gurgaon - 122 002, India, Phone: +91 124 235 1541, Fax: +91 124 235 1601
- **Metso Perú S.A.**  
Calle 5 Nro. 144, Urb. Industrial Vulcano, Ate, Lima 03, Peru, Phone: +51 1 313 4366, Fax: +51 1 349 0913
- **Metso Minerals (Chile) S.A.**  
Av. Los Conquistadores 2758, - Piso 3, Providencia, Santiago, Chile, Phone: +56 2 370 2000, Fax: +56 2 370 2039
- **Metso Brasil Indústria e Comércio Ltda.**  
Av. Independência, 2500 Éden, 18087-101 Sorocaba-SP - Brazil, Phone: +55 15 2102 1300



www.metso.com  
E-mail: minerals.info@metso.com  
Pumps information at  
www.metso.com/pumps